



100-347Vac
BLD-HM08D-YYY



EMERGENCY LED DRIVER

HIGH VOLTAGE OUTPUT
170VDC

CONSTANT POWER
EMERGENCY OUTPUT

Self Test

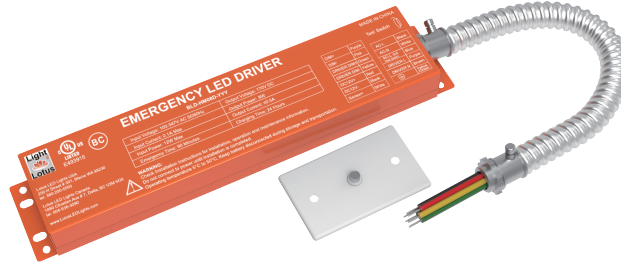

- CAUTION:**
- ① The Emergency LED driver must connect to 0-10V dimming wires(DIM+,DIM-) of the fixture if the LED luminaire power exceeds the emergency LED driver power.
 - ② When dimming to minimum,the LED luminaire power must be less than emergency driver's power.
 - ③ In emergency mode, double-click this test switch to turn off the current emergency stage.

MODEL NO.	Input Voltage	Input Current	Input Power	Output Voltage	Output Power	Application	Ambient Temperature
BLD-HM08D-YYY	100-347Vac 50/60Hz	0.1A max	12W max	170V dc	8W	≤60W(0-10V Dimmable Fixture) ≤8W LED Lamps without dimming function	5℃-50℃

Dimensions:

Case-10.43"×1.97"×0.96"(mounting center-9.91")

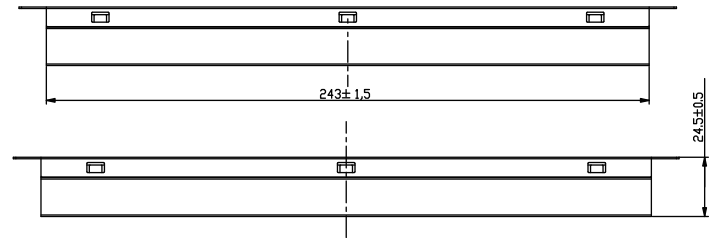
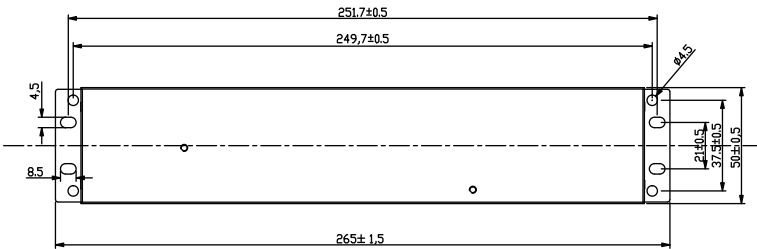

Wiring Diagram

Wiring 1: For LED Driver With Input Power Higher Than Emergency Output Power

0-10V Dimmable LED Driver + Dimmer Switch

Emergency Driver Dim+(Green) , Driver Dim-(Yellow) Have to connect with LED driver DIM+ and DIM-

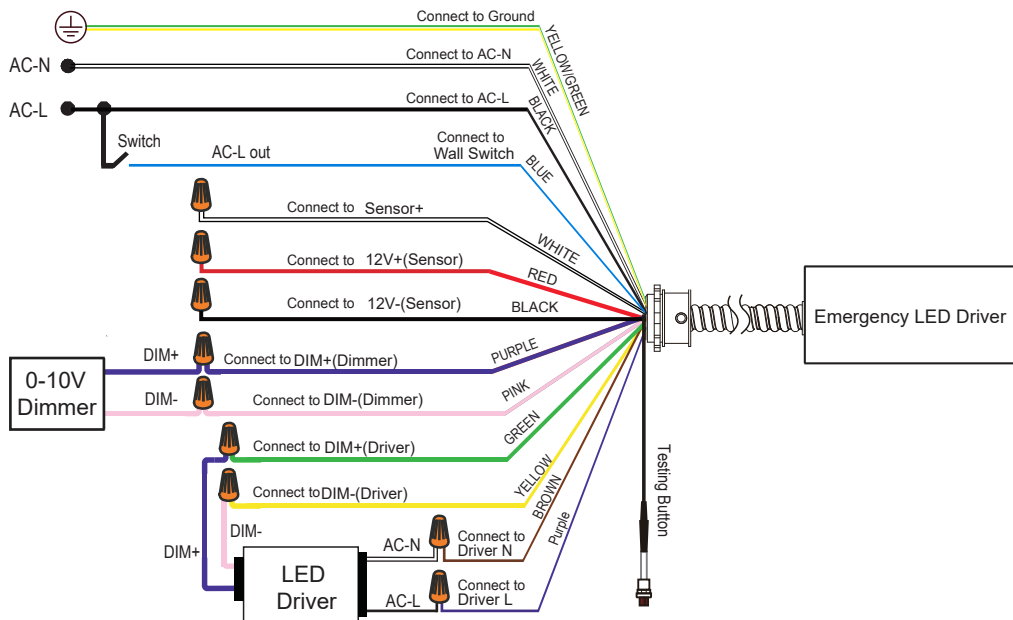

Wiring 2: For LED Driver With Input Power Higher Than Emergency Output Power

0-10V Dimmable LED Driver + Wall Switch

Emergency Driver Dim+(Green) Driver Dim-(Yellow) Have to connect to LED driver DIM+ and DIM-, If using 12Vdc sensor, the wires must connect to emergency LED driver's 12V sensor wires.

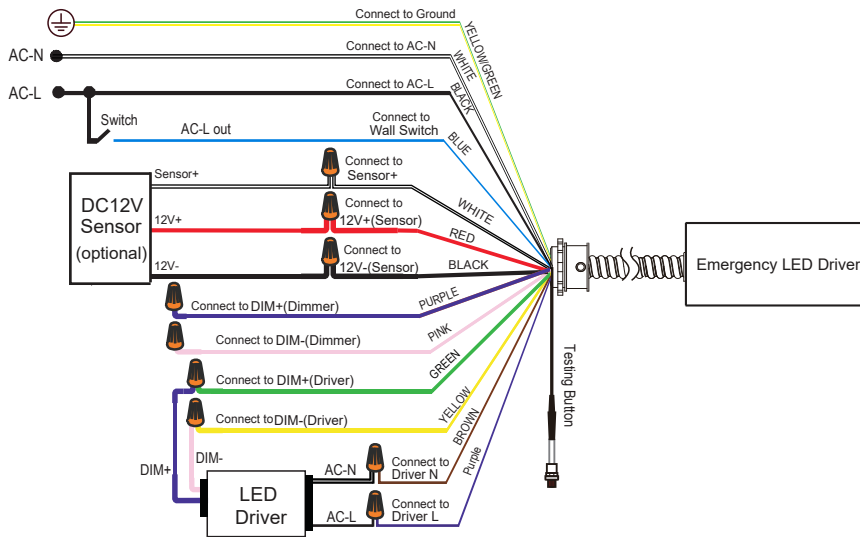

Wiring 3: For LED Driver With Input Power Less Than Emergency Output Power

NON Dimmable LED Driver

If using 12Vdc sensor, the wires must connect to emergency LED driver's 12V sensor wires.

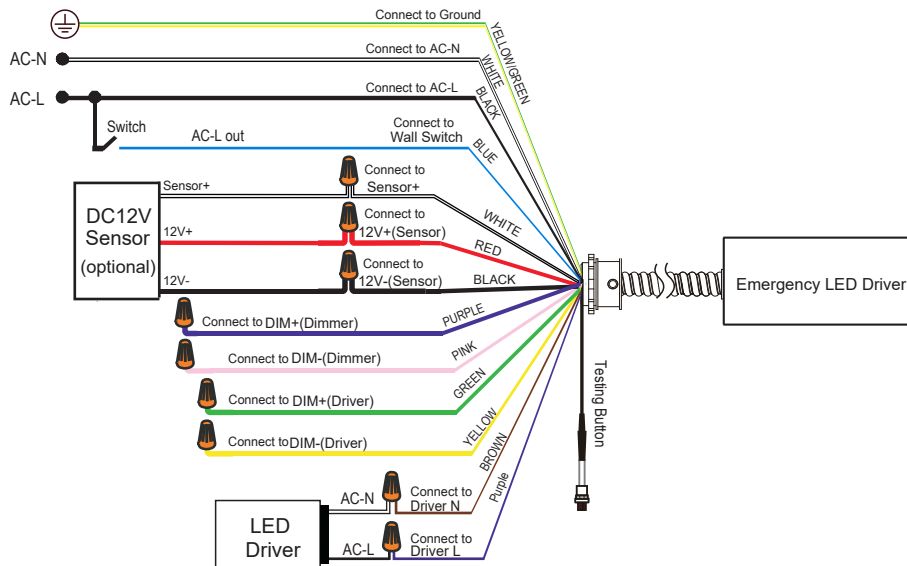

IMPORTANT SAFEGUARDS

When using electrical equipment, basic safety precautions should always be followed including the following

PLEASE READ AND FOLLOW ALL SAFETY INSTRUCTIONS.

CAUTION: RISK OF SHOCK-disconnect emergency and normal input power sources before servicing any equipment connected to this unit.

CAUTION: Risk of fire or electric shock-This emergency battery pack installation requires knowledge of luminaire and electrical systems.

CAUTION: Servicing of this equipment should be performed by qualified personnel only.

CAUTION: Before installation, make certain the AC power to fixture is off.

CAUTION: Verify that all replacement lamp types marked on the installed luminaire are also identified as suitable for use with this emergency battery pack.

CAUTION: Suitable for use in 5°C -50°C ambient temperatures. Max. mounting height: 27.2 ft.

IMPORTANT: An unswitched AC power source is required (100-347 VAC, 50/60 Hz). This device is designed for fixtures listed for dry and damp locations.

IMPORTANT: Please charge the battery consistently for >24 hours for the first time usage so as to activate the whole battery cells of discharging/charging duration.

IMPORTANT: Customers are advised to charge emergency LED drivers 24 hours every 6 months during storage, and which could be stocked for 1 year at most. If customers don't install and recharge for more than one year, the batteries may be damaged. This is not covered in the warranty, and we would charge for replacement.

IMPORTANT: Lighting fixture manufacturers, electricians, and end-users need to ensure product system compatibility test before using and final installation.

CAUTION: Do not use outdoors. Do not mount near gas or electric heaters.

CAUTION: Equipment should be mounted in locations and at heights where it will not be subjected to tampering by unauthorized personnel.

CAUTION: The use of accessory equipment is not recommended by the manufacturer may cause an unsafe condition.

CAUTION: The emergency battery pack is not for in an air-handling fixture.

CAUTION: Do not use this equipment for other than its intended use.